

7100

3200

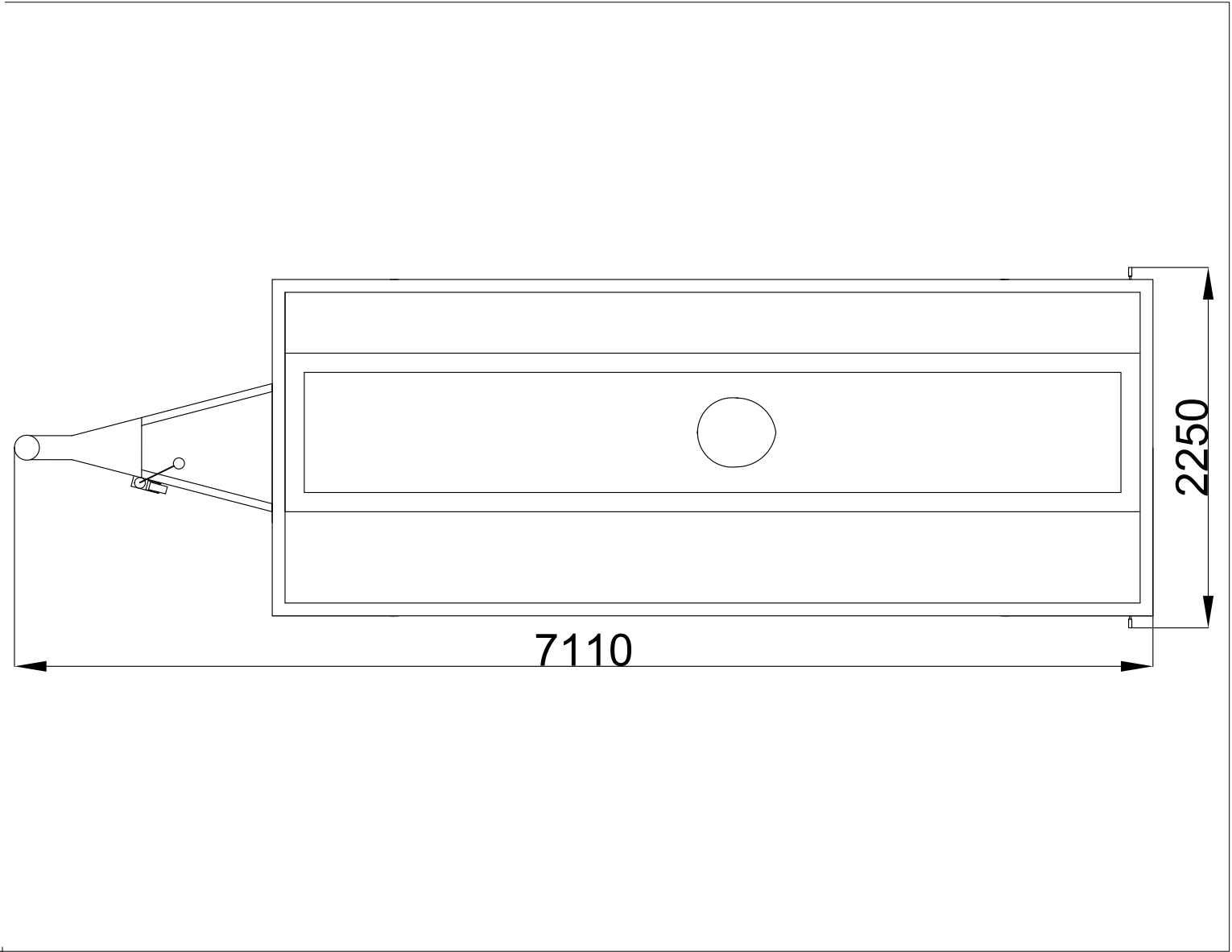

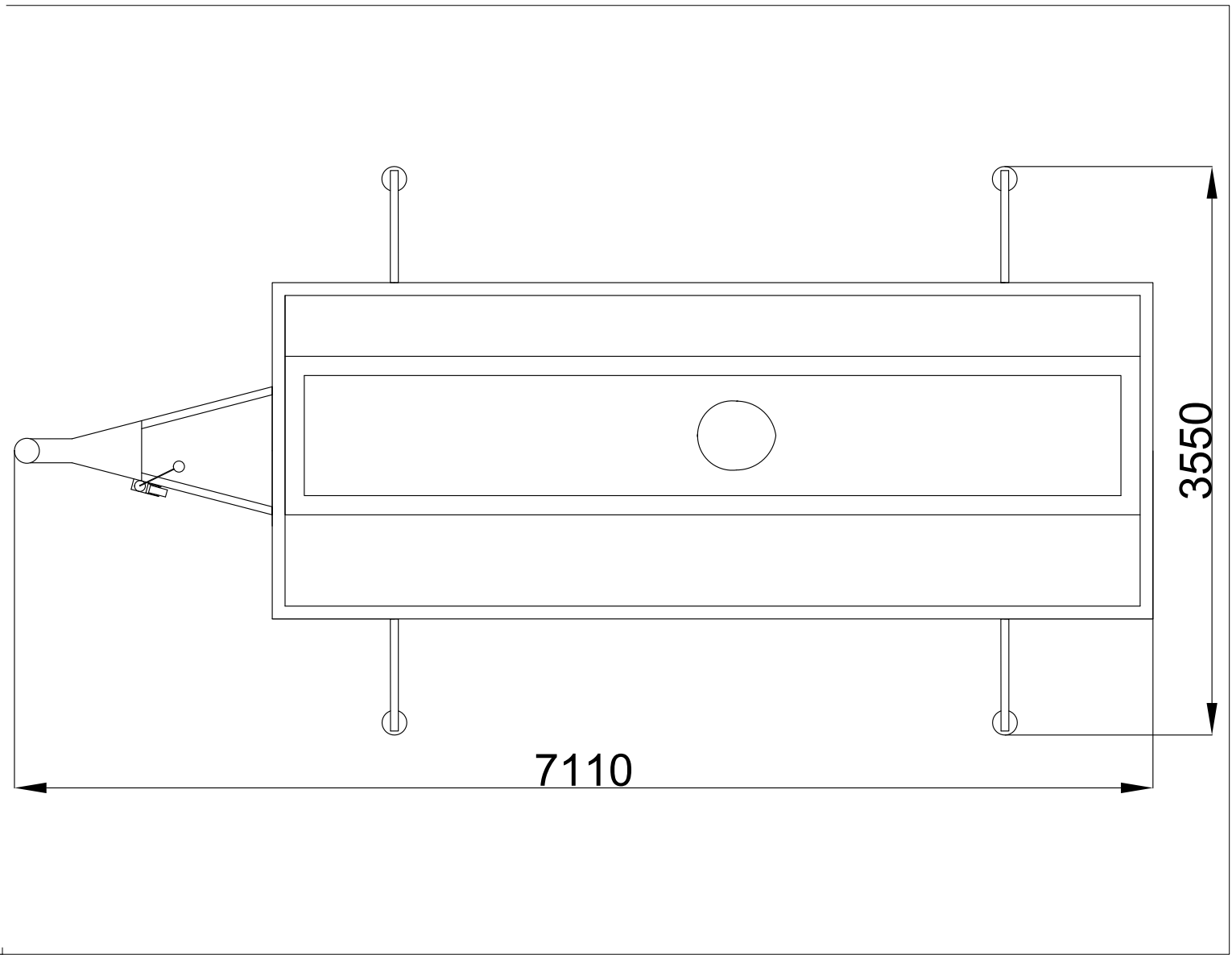

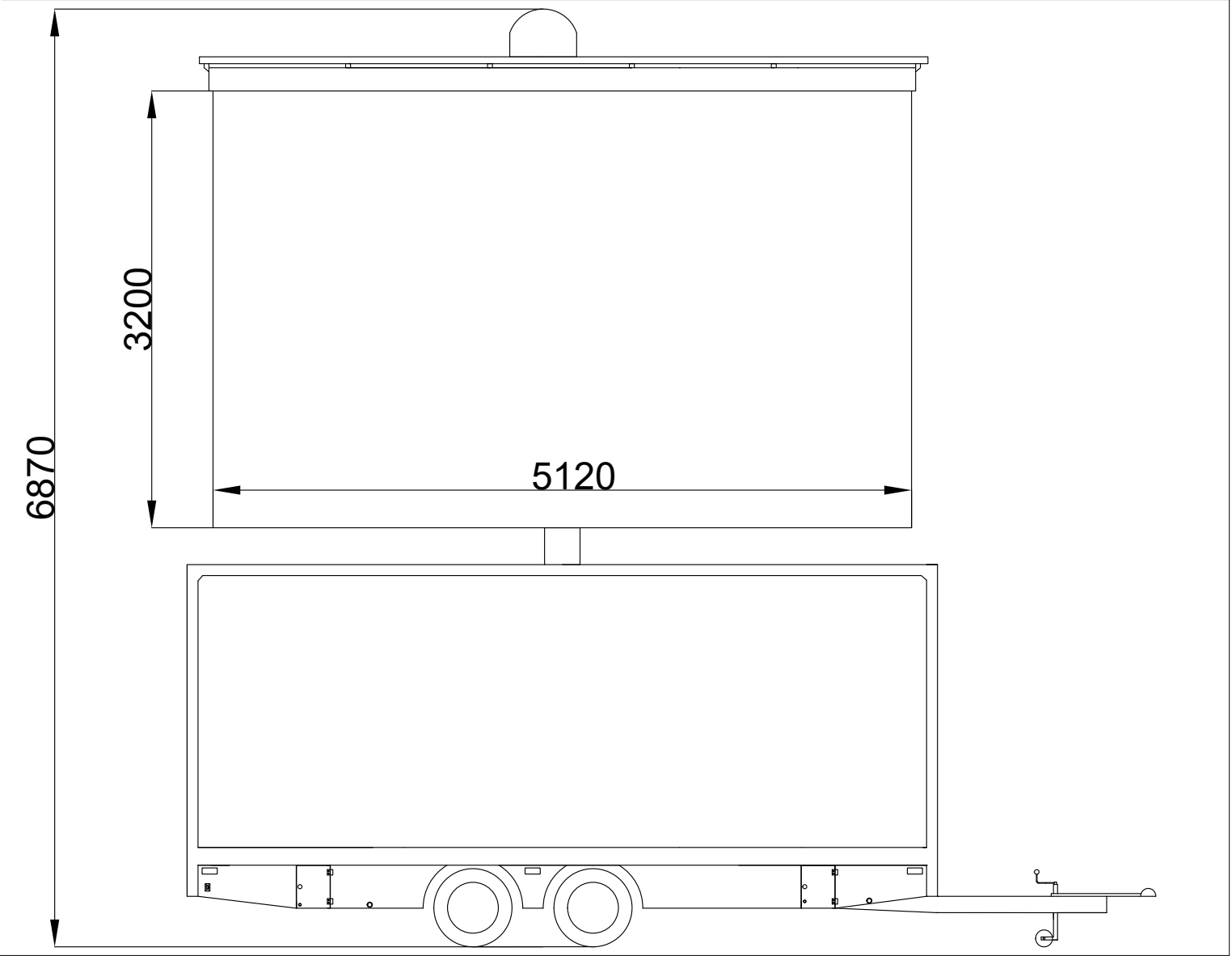

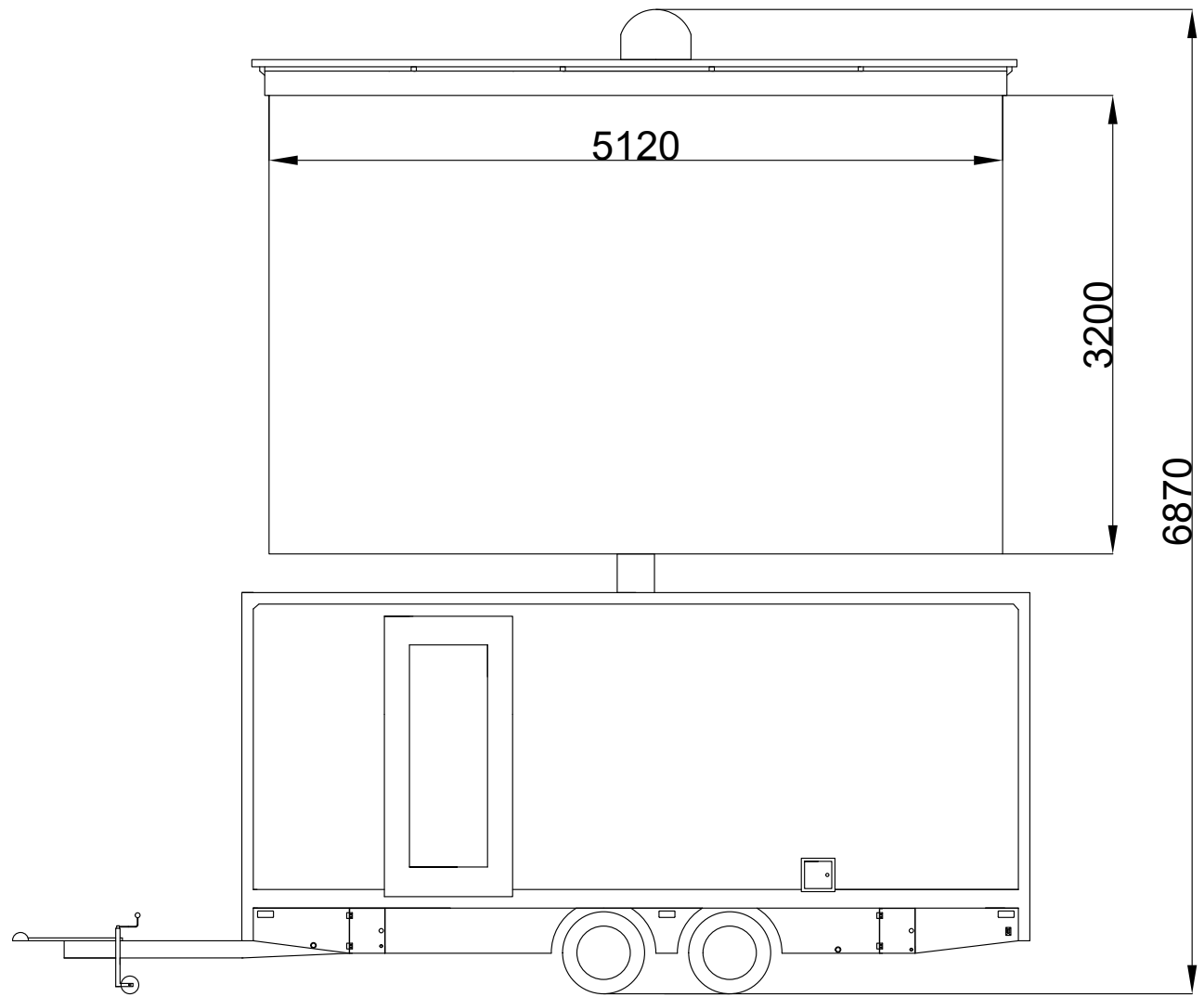

## Mobile Screen Hire Specification

Model	Size	Pixel Pitch	Configuration	Resolution (Physical)
SL5.9-OR	16.38sqm	5.926mm	SMD 2727	40000 pixles/m2

### Cabinet Specs

Module Size	320 x 320mm
Scanning Method	1/6 Scan
Module Resolution	54 x 54 Pixels
PCB Layer	4 Layer
Driving IC	MB15124
Module Maintenance Way	Black Screws
Cabinet Size	640 x 640 x 100mm
Cabinet Resolution	108 x 108 Pixels
Cabinet Weight	15Kg Per Cabinet
Cabinet Material	Die-Cast Aluminum
Cabinet Brightness	$\geq 5500\text{cd/m}^2$

Viewing Angle	Horizontal: 140° - Vertical: 140°
IP Rating	IP65
Refresh Rate	≧ 1920Hz
Grey Level	≧ 14bit
Lifetime	≧ 100000 Hours
Operating Environment	Temperature: -20°C~55°C; Humidity: 10%~90%
Power Supply	CE Certified
Input Voltage	220V/AC
MAX. Power Consumption	600w/m <sup>2</sup>
Ave. Power Comsumption	180w/m <sup>2</sup>
Input Power Frequency	50~60Hz
Software	Nova / Linsn / Others
Control Method	Synchronization display(to computer display)

Control System	Main controller + receiving controller + DVI card + CAT5/Fiber
Processor Inputs	DVI, HDMI, PAL/NTSC/SECAM;S-Video;VGA;RGB;Composite Video; SDI etc
Interface	Standard Ethernet
Transmission Distance	Multi mode fiber < 500m, Single mode fiber < 30Km, internet cable < 100m

## **Trailer & Power Specification**

Trailer Weight	3500Kg
Onboard Generator	16.5 Kva
Generator Fuel	Diesel
Generator Fuel Usage	5.5 Litres Per Hour
Hard Power Requirements	32a 3/phase 5 pin 415V
Wind Speed Warning Alarm	12 m/ps – (26mph)
Wind Speed Max	15 m/ps (33mph)